



### Features

- MOSFET output
- DC control
- Low on-state resistance
- Photo isolation
- 2500V dielectric strength
- Environmental friendly product (RoHS compliant)

## DESCRIPTION

HFS33 Series offer 3 to 32VDC input control and use MOSFET technology to provide an economical and reliable method of switching medium and high power DC loads. These relays combine low on-state resistance with fast switching times. They are available with switching currents 50A at 30V, 100A at 30V, 40A at 50V, 80A at 50V and 20A at 100V, 40A at 100V, 50A at 150V, 10A at 200V, 40A at 200V, 10A at 400V, 7A at 500V and 12A at 500V etc.

## PRECAUTIONS

1. Inductive loads must be diode suppressed.
2. When choosing a SSR, please notice the actual load current and working ambient temperature. To use the SSR correctly, please refer to CHARACTERISTIC DATA and make sure the heat sink size when it works in full load current.
3. Apply heat-radiation silicon grease of a heat conductive sheet between the SSR and heat sink. There will be a space between the SSR and heat sink Attached to the SSR. Therefore, the generated heat of the SSR cannot be radiated properly without the grease. As a result, the SSR may be overheated and damaged or deteriorated.
4. Tighten the SSR terminal screws properly. If the screws are not tight, the SSR will be Damaged by heat generated when the power in ON. Perform wiring using the tightening torque shown in the right table.

Screw size	Recommended tightened torque
M3	0.58 to 0.98 N·m
M4	0.98 to 1.37 N·m

## INPUT (Ta = 25°C)

Control voltage range	3 to 32VDC (Without LED) 4 to 32VDC (With LED)
Must operate voltage	3VDC (Without LED) 4VDC (With LED)
Must release voltage	1.0VDC
Max. input current	28mA (at 32VDC)
Max. reverse voltage	-32VDC

## GENERAL (Ta = 25°C)

Dielectric strength (Input/Output/Base)		2500VAC, 50/60Hz, 1min
Insulation resistance		1000MΩ (at 500VDC)
Ambient temperature	Operating	-30°C to 80°C
	Storage	-30°C to 100°C
Unit weight		Approx. 80g

## OUTPUT (Ta = 25°C)

	D-30D□M		D-50D□M		D-100D□M		D-150D□M		D-200D□M		D-400D□M		D-500D□M	
	50	100	40	80	20	40	50	10	40	10	7	12		
Load voltage range	0~30VDC		0~50VDC		0~100VDC		0~150VDC		0~200VDC		0~400VDC		0~500VDC	
Load current range	0.02 -50A	0.02 -100A	0.02 -40A	0.02 -80A	0.02 -20A	0.02 -40A	0.02 -50A	0.02 -10A	0.02 -40A	0.02 -10A	0.02 -7A	0.02 -12A		
Max. off-state leakage current	0.1mA		0.1mA		0.1mA		0.1mA		0.1mA		0.1mA			
Max. on-state voltage drop	0.35V	0.35V	0.64V	0.64V	1.5V	1.5V	0.6V	1V	1V	2.4V	1.9V	1.5V		
Max. on-state resistance	7mΩ	3.5mΩ	16mΩ	8mΩ	75mΩ	37.5mΩ	12mΩ	105mΩ	35mΩ	0.24Ω	0.26Ω	0.125Ω		
Max. turn-on time													1ms	
Max. turn-off time													0.5ms	
Max. surge current (10ms)	120A	240A	100A	200A	80A	160A	200A	40A	130A	40A	30A	40A		



HONGFA RELAY

ISO9001, ISO/TS16949, ISO14001, OHSAS18001, IECQ QC 080000 CERTIFIED

2009 Rev. 1.01

## ORDERING INFORMATION

Type	HFS33 / D- 200 D 40 M -L (XXX)					
Input voltage	D: 3 to 32VDC (Without LED) 4 to 32VDC (With LED)					
Load voltage	30: 30V 50: 50V 100: 100V 150: 150V 200: 200V 400: 400V 500: 500V					
Load voltage form	D: DC					
Load current	7: 7A 10: 10A 12: 12A 20: 20A 40: 40A 50: 50A 80: 80A 100: 100A					
Output component	M: MOSFET output					
LED indicator	L: With LED Nil: Without LED					
Customer special code						

**Notes:** Available parts are: HFS33/D-30D50M-□, HFS33/D-30D100M-□, HFS33/D-50D40M-□, HFS33/D-50D80M-□, HFS33/D-100D20M-□, HFS33/D-100D40M-□, HFS33/D-150D50M-□, HFS33/D-200D10M-□, HFS33/D-200D40M-□, HFS33/D-400D10M-□, HFS33/D-500D7M-□, HFS33/D-500D12M-□.

## OUTLINE DIMENSIONS, WIRING DIAGRAM AND MOUNTING HOLES

Unit: mm

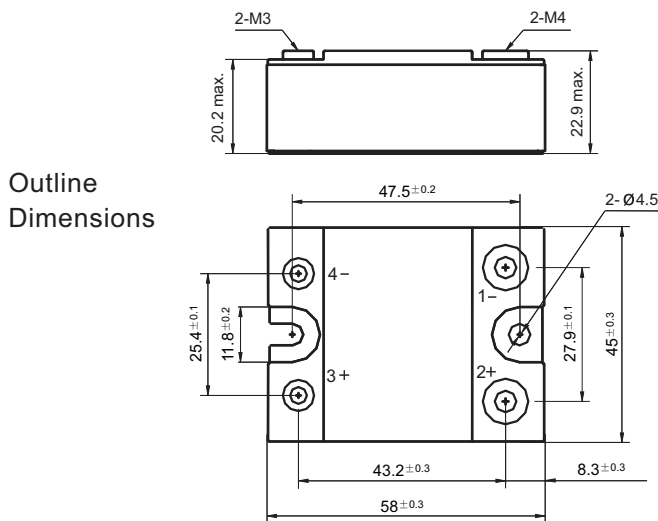

### Mounting Hole Layout

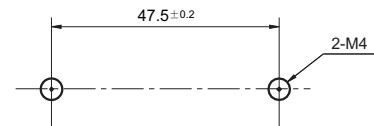

### Wiring Diagram

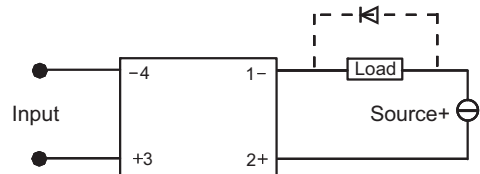

## CHARACTERISTIC CURVES

Max. Load Current vs. Ambient Temp. (D-200D10M)

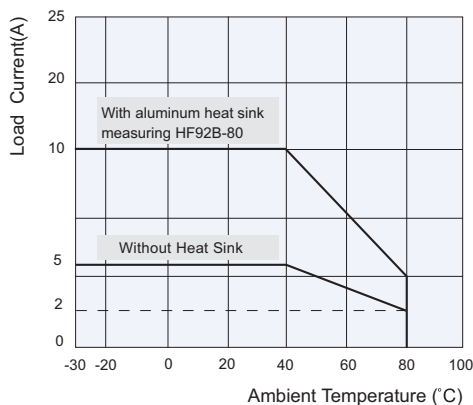

Max. Load Current vs. Ambient Temp. (D-100D40M, D-200D40M)

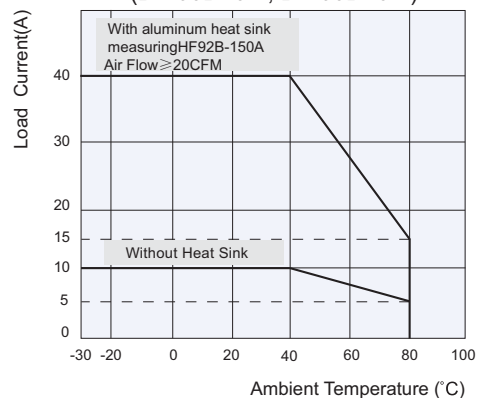

## CHARACTERISTIC CURVES

Max. Load Current vs. Ambient Temp.(D-50D80M)

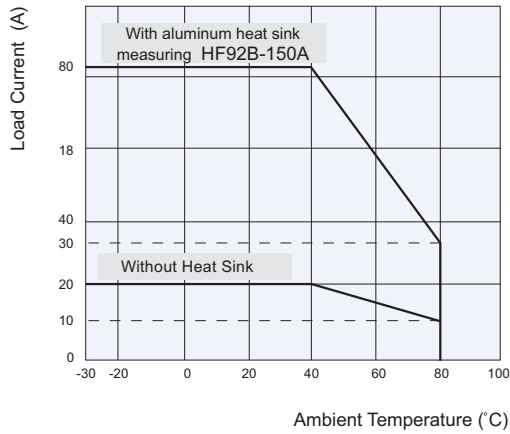

Max. Load Current vs. Ambient Temp.(D-30D100M)

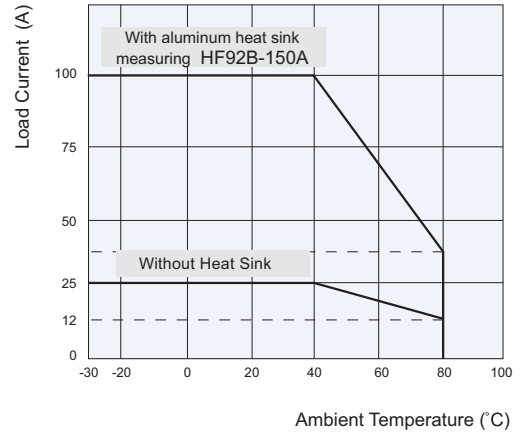

Max. Load Current vs. Ambient Temp.(D-400D10M)

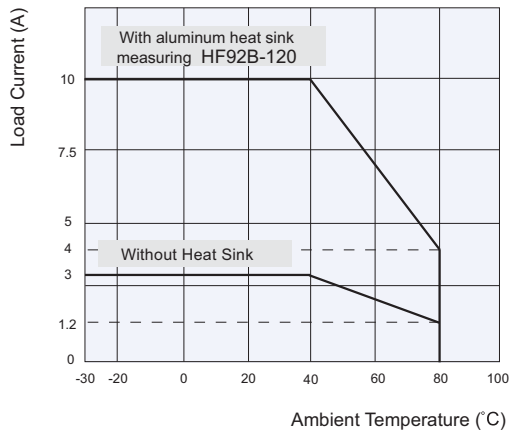

Max. Load Current vs. Ambient Temp.(D-100D20M)

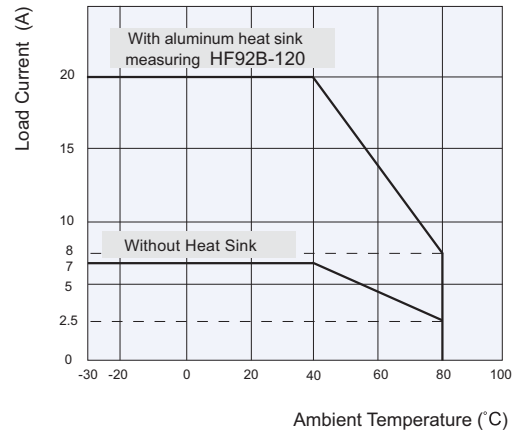

Max. Load Current vs. Ambient Temp.(D-50D40M)

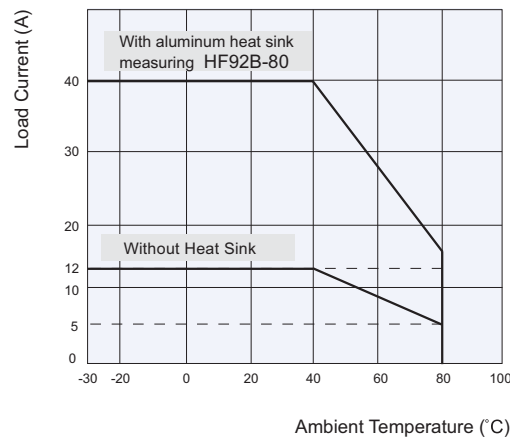

Max. Load Current vs. Ambient Temp.(D-30D50M)

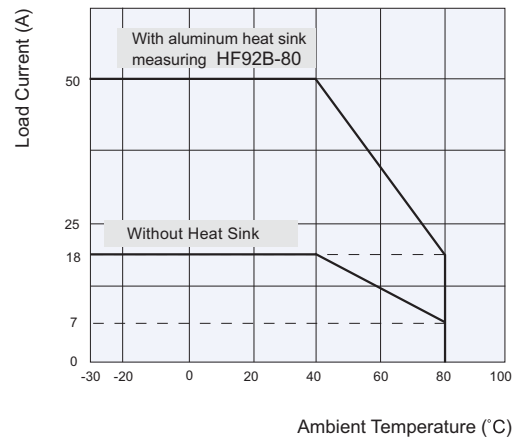

## CHARACTERISTIC CURVES

Max. Load Current vs. Ambient Temp.(D-150D50M)

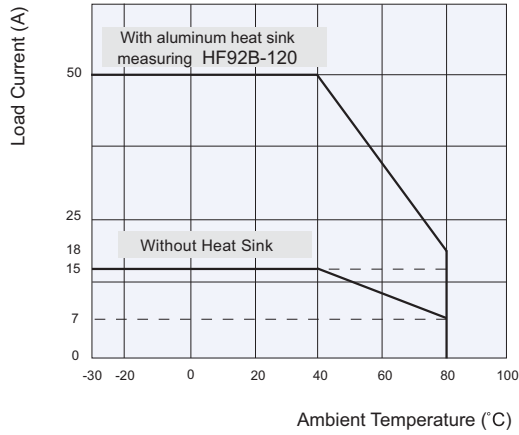

Max. Load Current vs. Ambient Temp. (D-500D7M)

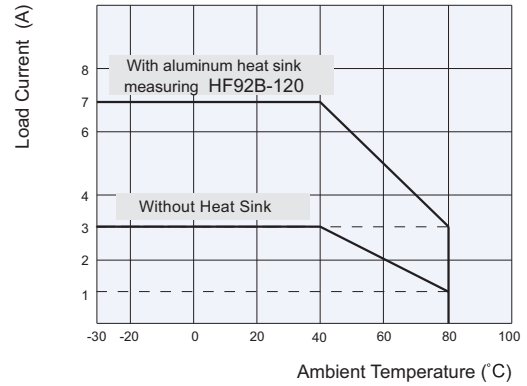

Max. Load Current vs. Ambient Temp. (D-500D12M)

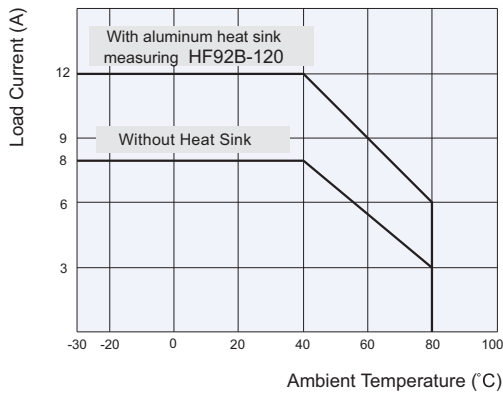

Max. Permissible Non-repetitive Peak Surge Current vs. Continuance Time

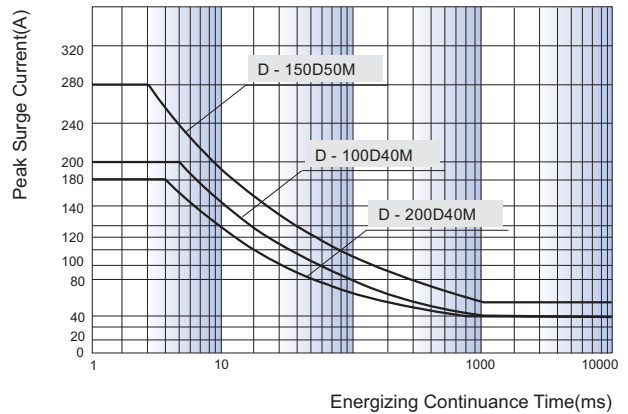

Max. Permissible Non-repetitive Peak Surge Current vs. Continuance Time

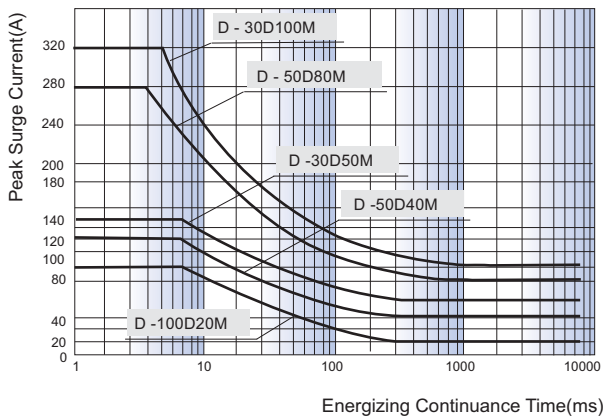

Max. Permissible Non-repetitive Peak Surge Current vs. Continuance Time

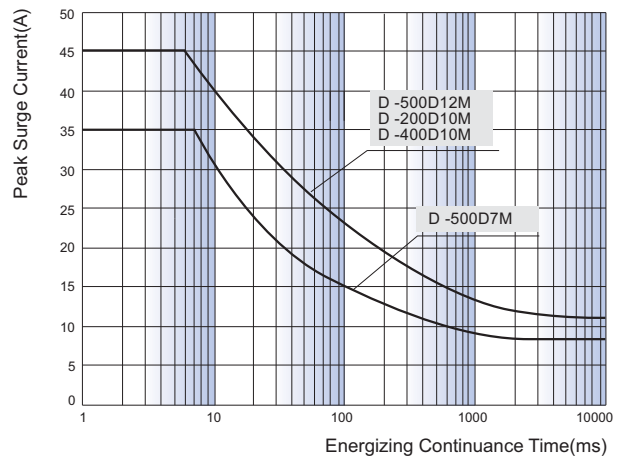

### Disclaimer

This datasheet is for the customers' reference. All the specifications are subject to change without notice.

We could not evaluate all the performance and all the parameters for every possible application. Thus the user should be in a right position to choose the suitable product for their own application. If there is any query, please contact Hongfa for the technical service. However, it is the user's responsibility to determine which product should be used only.